

ELSEWHEREPODS.COM

elsewhere



Studios, tiny homes & luxury eco-tourism accommodation

Empowering customers to rethink modular building and design, connecting occupants with their environment seamlessly and comfortably.

Pod style outdoor living which will inspire owners to imagine the possibilities; whether its luxury eco-tourism accommodation, or a stylish and customisable home studio or office.

BENEFITS

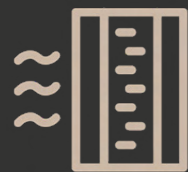

INSULATION
PERFORMANCE



PLUG &
PLAY



DELIVERED
AND INSTALLED



CONTEMPORARY
DESIGN



VENTILATION
SYSTEM



COST
EFFECTIVE





Modular Design

Our modular system has been developed to allow for almost unlimited customisation. Every wall panel included in our standard designs can be swapped out for an alternate panel type, window or door type, colour or finish.

There is almost no limit to the design customisations we can achieve with our system, so we encourage our customers to “tell us what the dream looks like” in our design meeting.

Our supply chain

Elsewhere Pods has developed a unique and innovative supply chain solution which resolves one of the largest challenges in the prefabricated building industry - Logistics.

Our simple and unique process:

- Our factory prefabricates the materials to our customer's specs
- We test assemble the product in the factory
- We disassemble the product and flat pack into crates for shipment
- Product is shipped direct to the customer's property
- Our team arrives at the customer's property and install the product within 2-4 days for standard designs.

This whole process from order placement to finished installation usually takes 12 weeks, and is included in the purchase price when installed in metro areas.



Our process

- Initial consultation - We get to know all about you, your property and your project. Our Customer Success Team can book you in for on site inspection of a display, or even a virtual tour. We run through all of the options and answer all of your questions.
- Design meeting - Once you've got a feel for our system we get together to design the dream. We'll draw it up together and make suggestions on how to get the most out of our products and your property.
- Quoting - Once we have the draft design, we provide you with an initial quote. We then discuss any required changes, material selections, add ons and substitutions. We can also discuss leasing options at this stage.
- Order agreement / deposit payment - We draft up and send the agreement for signing. Payment of a 5% holding deposit locks your pricing in for a maximum of 3 months, alternatively payment of a 30% deposit means we can place the order into production.
- Delivery and installation - Final payment is made upon delivery to site, then we install and handover your dream studio or tiny home!



A man wearing a black beanie and a plaid shirt is sitting on a white sofa inside a tiny home pod, reading a book. The pod has large glass windows and a black frame. The interior is furnished with a white sofa, a glass coffee table, and a white shelving unit. The exterior of the pod is surrounded by lush greenery and trees. The scene is captured from a slightly elevated angle, looking through the open doorway of the pod. The lighting is bright and natural, suggesting a sunny day. The overall atmosphere is peaceful and serene, highlighting the connection between the tiny home and its natural surroundings.

elsewhere

Elsewhere Pods are designed to inspire. Our range of studios and tiny homes seamlessly connect occupants to the environment.

STUDIO OFFICES



- Unlimited customisation
- Available in 6 sizes 2.7m, 4m, 6m, 8m, 10m & 12 long units.
- Standard width and height of 2.4m x 2.4m (custom widths available on request)
- Price includes delivery and installation
- Tiny home upgrades including kitchenette, bathrooms and trailers available
- Ask about our lease options

2.7m



4m



6m

STUDIO OFFICES & TINY HOMES

The future of flexible work, living spaces, and eco-tourism accommodation has arrived with Elsewhere's prefabricated modular designs.



8 m

Double Wide



10 m

Deck & Pergola



12 m

Design your own space

Utilising premium materials and modular design, there are endless possibilities to customise your luxury escape or office space.



TECHNICAL FEATURES

Frame

Titanium Magnesium Alloy with a modern matte finish in a selection of colours.

Insulation/Panel

CEP aluminium film composite thermal insulation with sandwich construction and internal insulation.

Electrical and Plumbing

Sandwich panel construction allows for easy electrical and water connections.

- Price includes delivery and installation
- Tiny home upgrades including kitchenette, bathrooms and trailers available
- Ask about our lease options



Ventilation

Ventilation and air-conditioners systems included in purchase price.

Premium fittings included

Standard installation includes premium lighting, ventilation system, air-conditioner, kitchenette and bathroom fixtures.

Glass

Double glazed and tempered glass with a large argon filled cavity, low-e treatment film and includes a thermal break for insulation. Ask about our triple glazing for ultra high performance!

MAKE THE MOST OF YOUR
VIEWS BY ADDING A
ROOFTOP BALCONY





STANDARD INCLUSIONS:

- Delivery & installation to metro areas
- 2.5kw Split system heater/airconditioner
- Double glazed, tempered, mute, Low-e treated, thermally broken glass panels
- Internal electrical components installed by certified/licenced trades



DESIGNING AND
MANUFACTURING
INSPIRING
SPACES



ENDLESS
POSSIBILITIES
FOR LUXURY ECO-TOURISM
ACCOMMODATION

ACTIVATION AND EVENTS SPACES



SPECS AND STRUCTURAL DRAWINGS

2.7 m



4 m

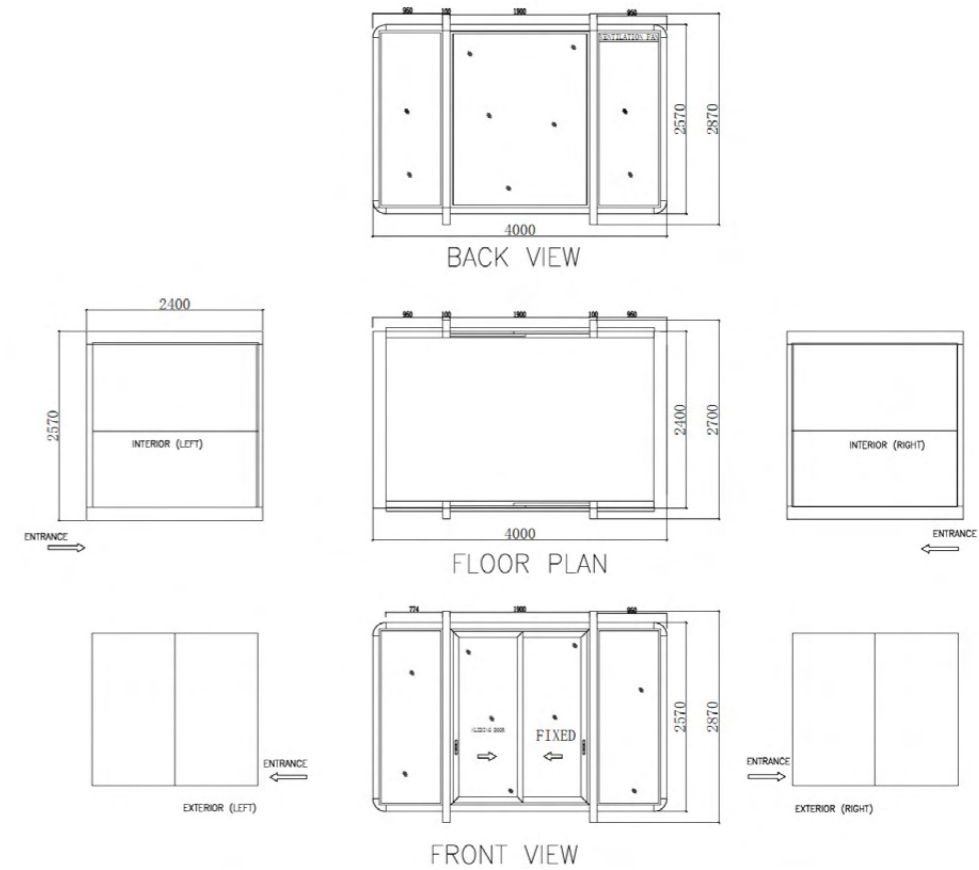
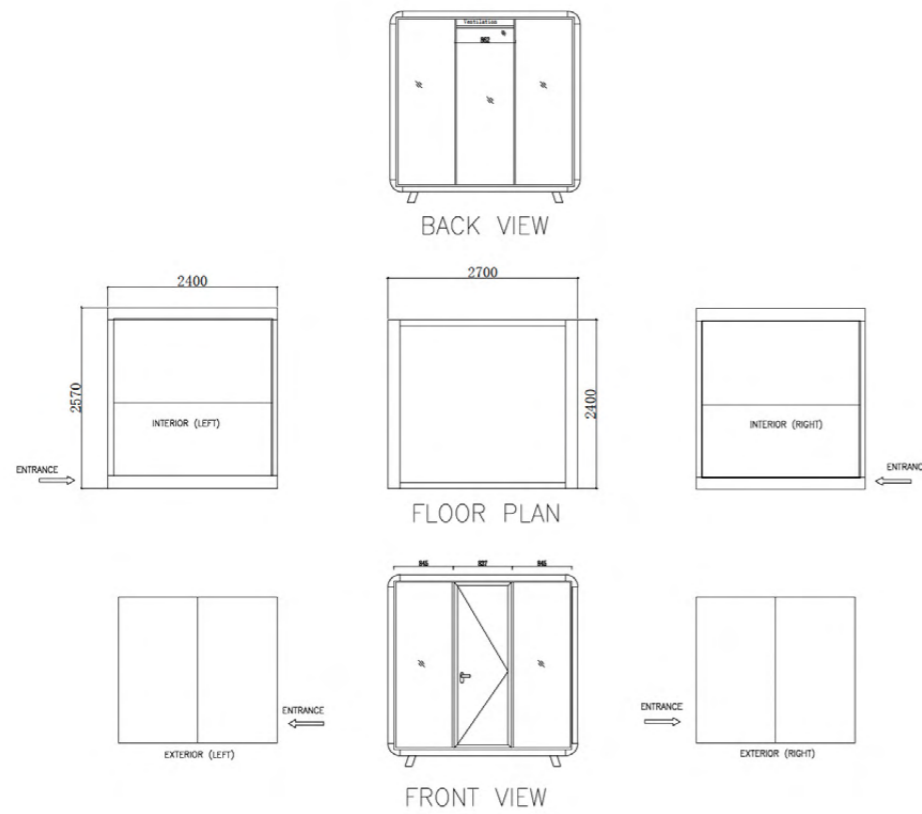

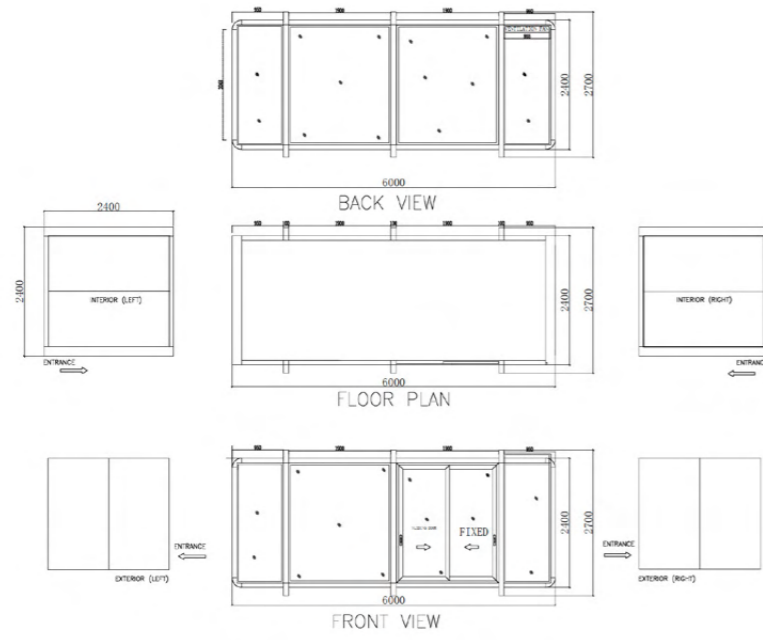

6 m



8 m

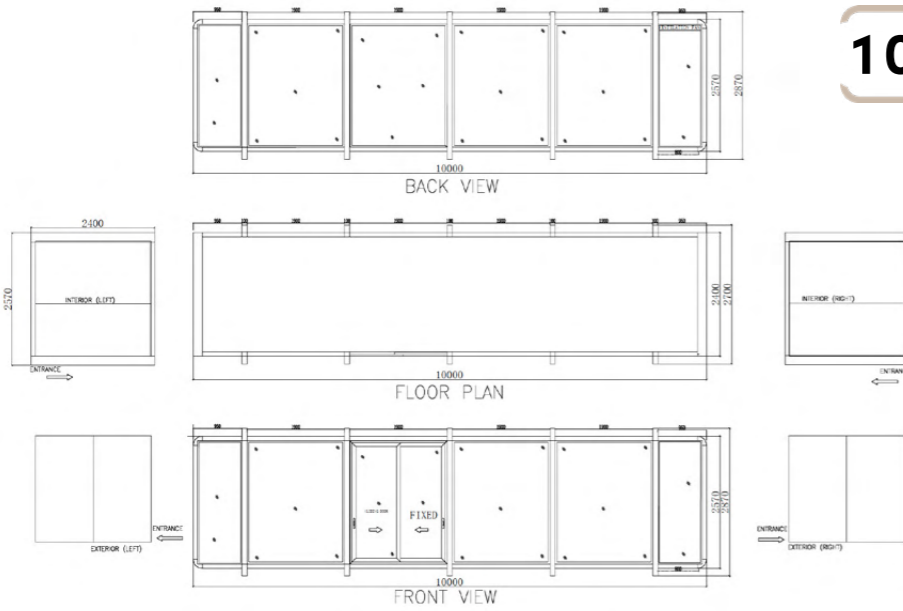
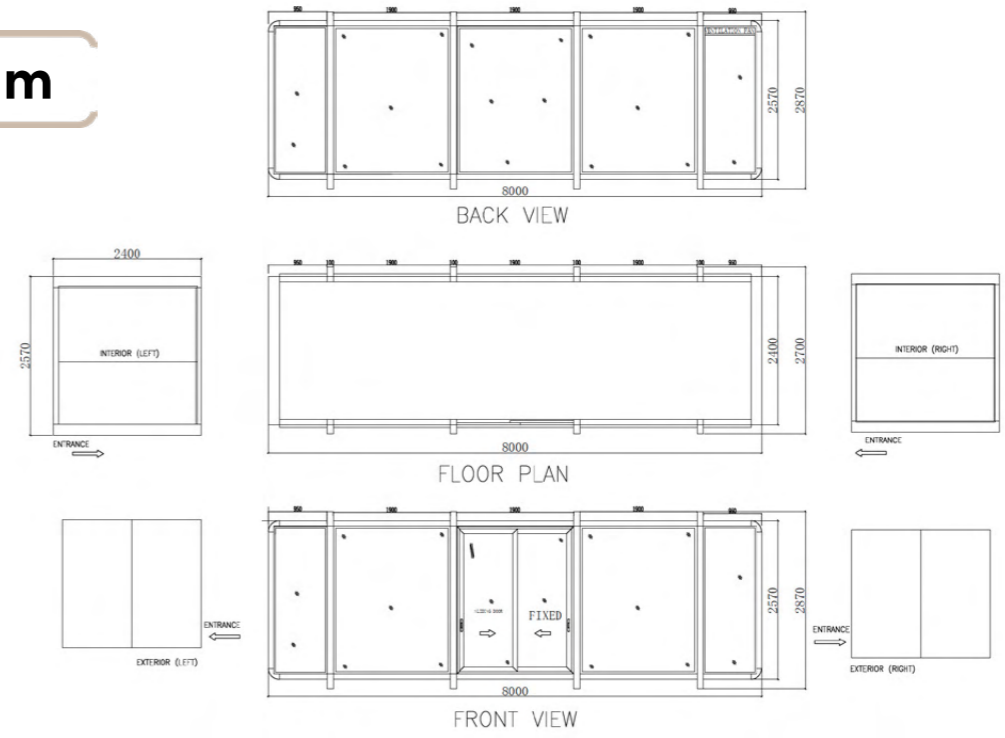

10 m



ECO-TOURISM
ACCOMMODATION

MICRO HOMES (4m)

Utilising premium materials and modular design, there are endless possibilities to customise your luxury escape.



ECO-TOURISM ACCOMMODATION



TINY HOMES (6m)

Utilising premium materials and modular design, there are endless possibilities to customise your luxury escape.

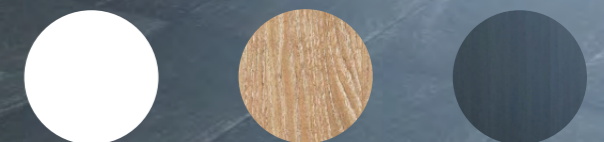

STANDARD FLOORPLANS

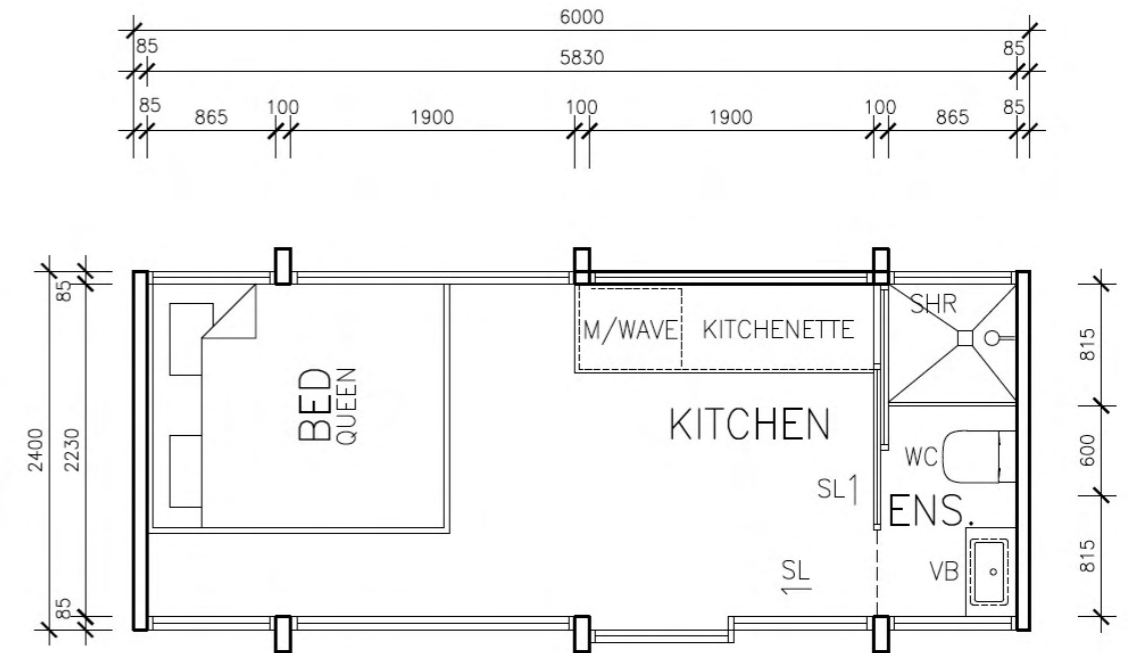
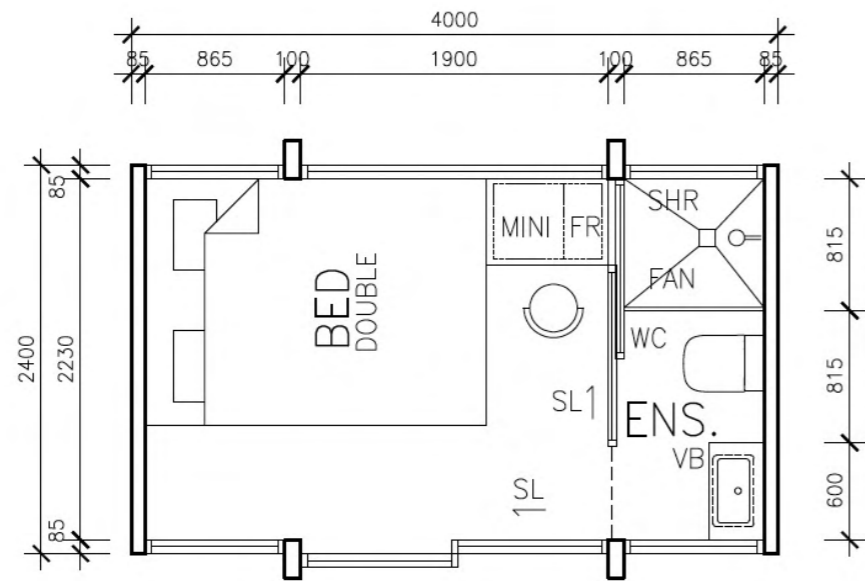

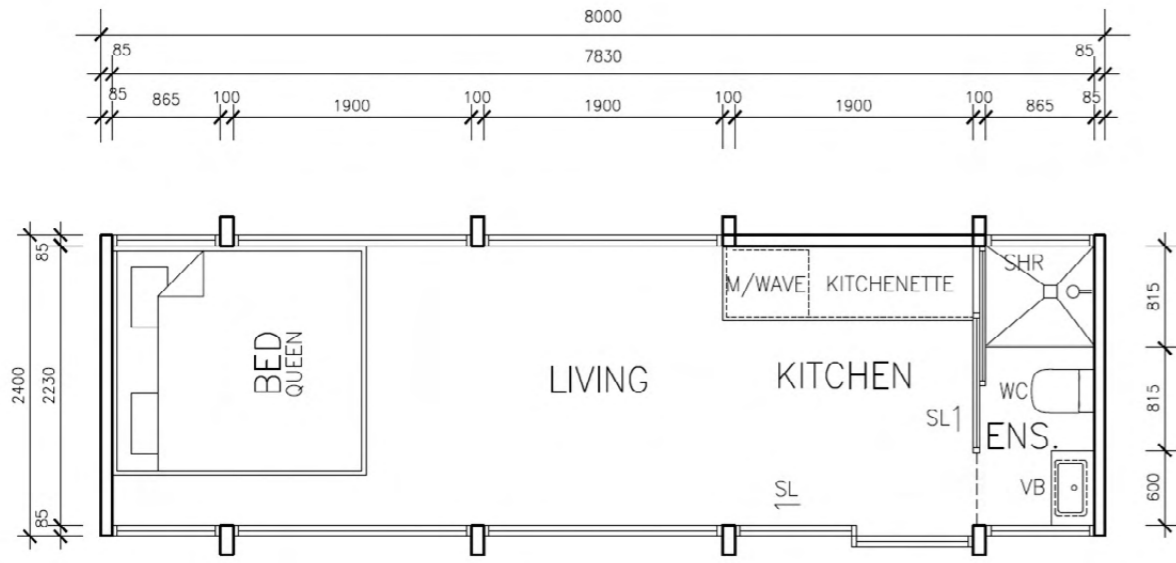

TINY HOMES (8m)



TINY HOMES (10m)

Utilising premium materials and modular design, there are endless possibilities to customise your luxury escape.

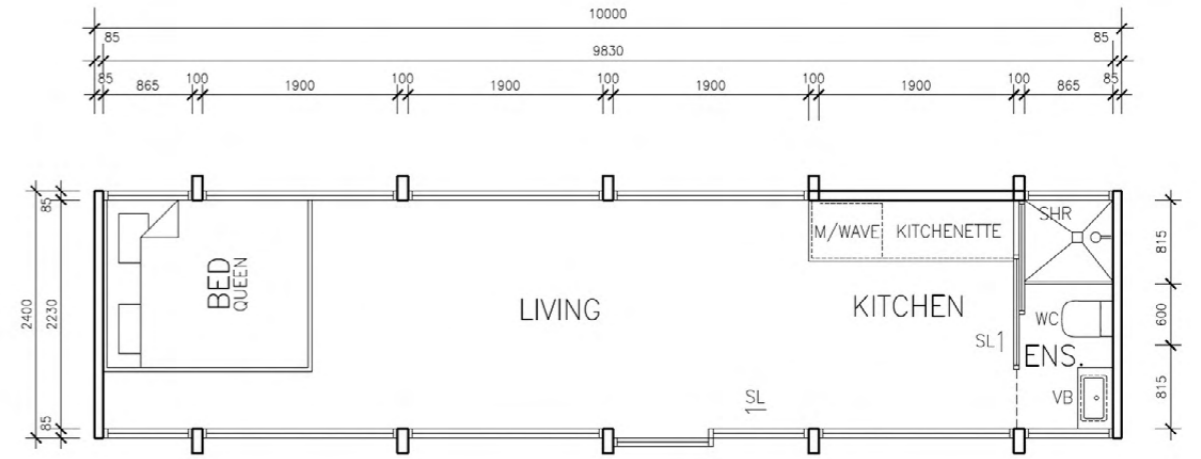

TINY HOMES (12M)

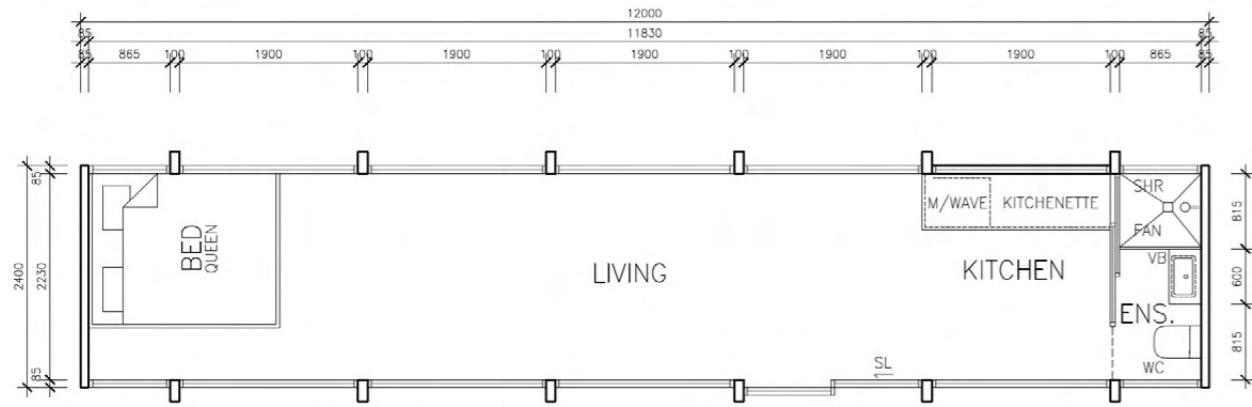

STANDARD INCLUSIONS:

- Delivery & installation to metro areas
- Kitchenette - sink, mixer tap, cabinets as per 'standard' design.
- Bathroom - Shower base and rail system, vanity, mirror, slimline toilet, integrated exhaust fan.
- 2.5kw Split system heater/airconditioner
- Moru / frosted glass in bathroom + Moru / frosted glass internal sliding door
- Double glazed, tempered, mute, Low-e treated, thermally broken glass panels
- Internal electrical and plumbing components installed by certified/licenced trades





COLOUR PALETTE



INTERNAL AND
EXTERNAL
PANEL COLOR



Matte White

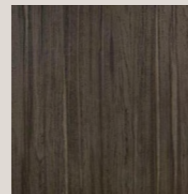

Cuba Grey

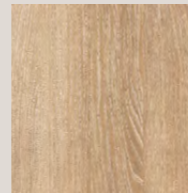

Cedar

EXTERNAL FRAME:
TITANIUM
MAGNESIUM ALLOY
IN MATTE FINISH



Matte White



Matte Black

OPTIONS + UPGRADES PANEL SELECTIONS

Elsewhere Pods has developed a range of stunning and cost effective ways to increase the livable space of our studios and tiny homes.

Decks:

Our decks integrate seamlessly with the facade of the pod and match the modern minimalist design aesthetics. The materials match those of the pod and the decking itself is made of low maintenance composite wood.

Pergolas:

Elsewhere has designed a pergola system which connects to the pod structure and the deck. The pergola includes an electronic louvre system to allow sunshine or collect water depending on weather conditions, and also has LED lights integrated as standard.

Rooftop Balconies:

Our modular products can be stacked or customised to include rooftop balconies and staircase systems. These options allow occupants to capitalise on roof space to create stunning and easily accessible views.



winners!



OMG! FUND

Elsewhere recently won a global design competition run by Airbnb called the OMG! Fund. Elsewhere was selected from over 10,000 entrants to be funded by Airbnb in building this concept called 'Kangaroom'. The structure will be located in Daylesford Victoria and will be available to guests on Airbnb by the end of 2023.



TINY HOMES (10m)

Integrated Deck
& Pergola Options

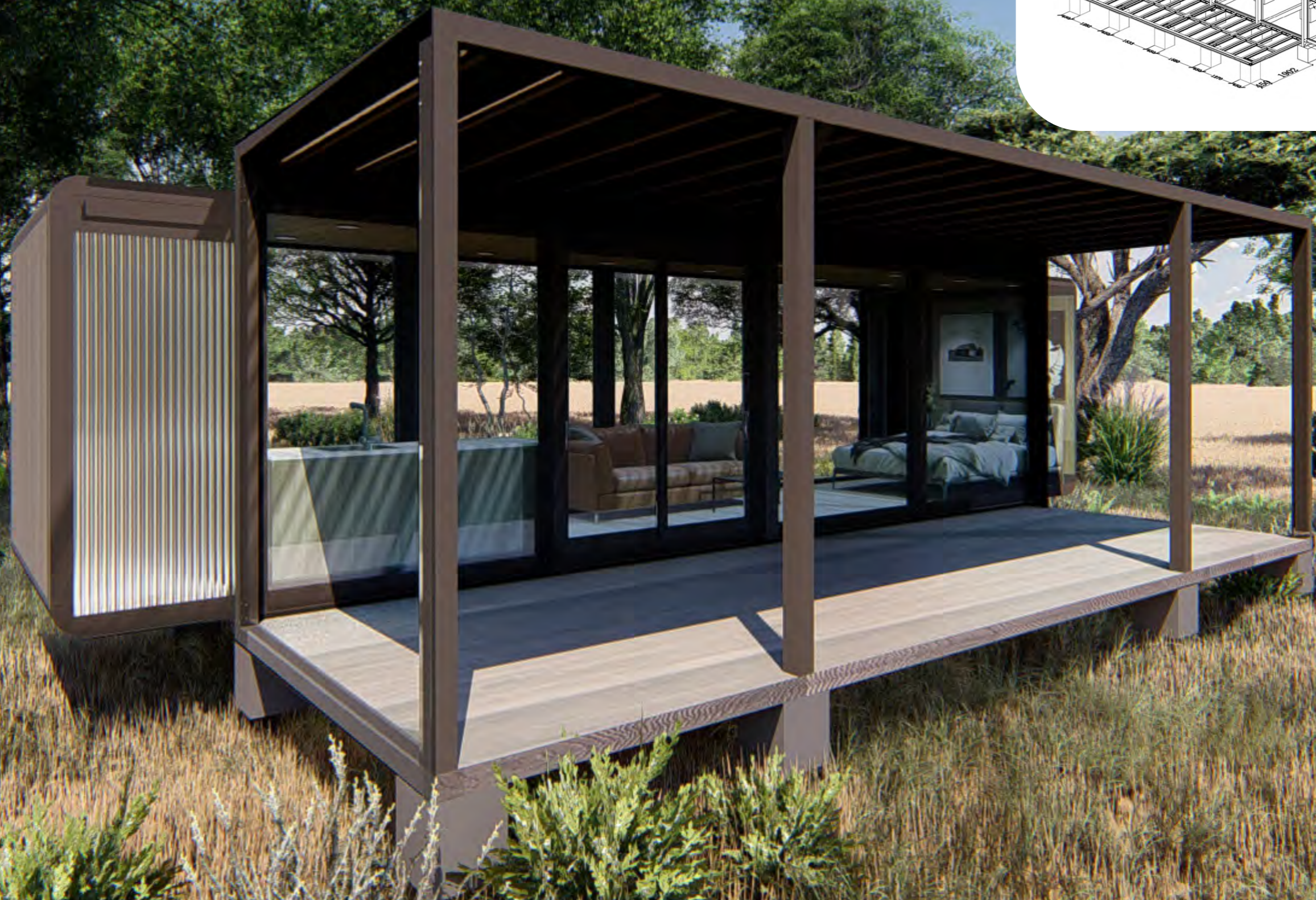
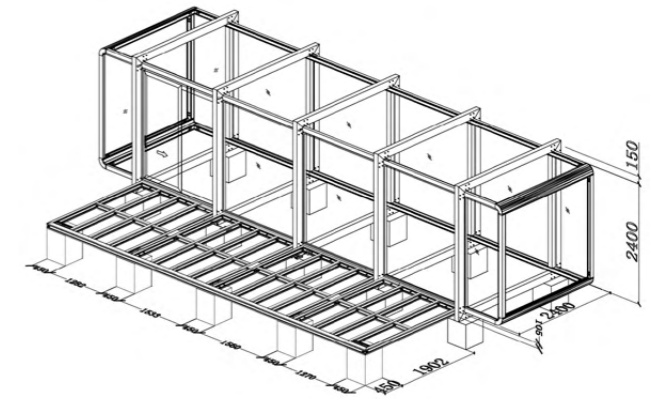

PANEL, WINDOW & DOOR OPTIONS

LARGE PANELS (1900x2400)mm

SMALL PANELS (865x2400)mm

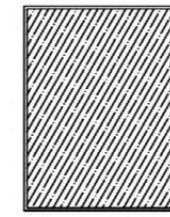

Glass

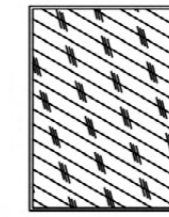

Solid

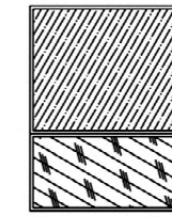

Half Solid

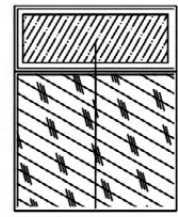

3/4 Solid

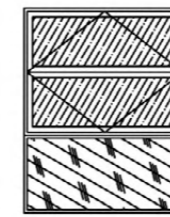

Vertical Bi-fold

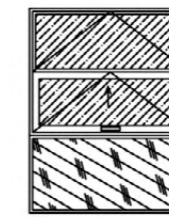

Vertical Sliding

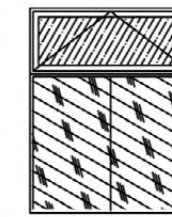

3/4 Awning

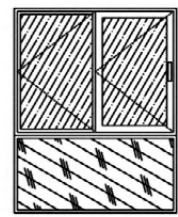

Half Sliding



Glass



Half Solid



Solid



3/4 Solid



Vertical Sliding



Half awning



3/4 Awning



Vertical Bi-fold

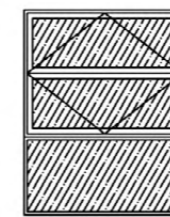

Vertical Bi-fold

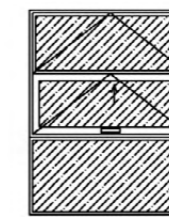

Vertical Sliding

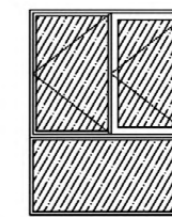

Half Sliding



Half Sliding



Half Awning



Vertical Bi-fold



Casement Door

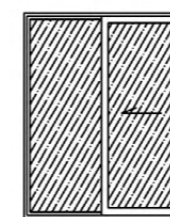

Sliding door

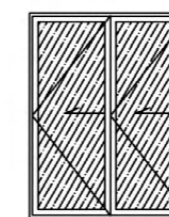

Bi-fold door



Smart Lock

KITCHENETTE OPTIONS



FRIDGE KITCHENETTE

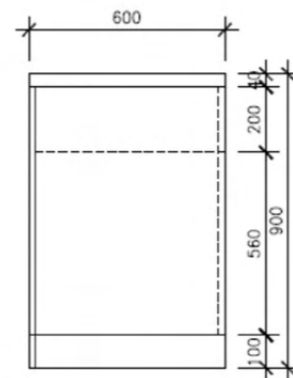
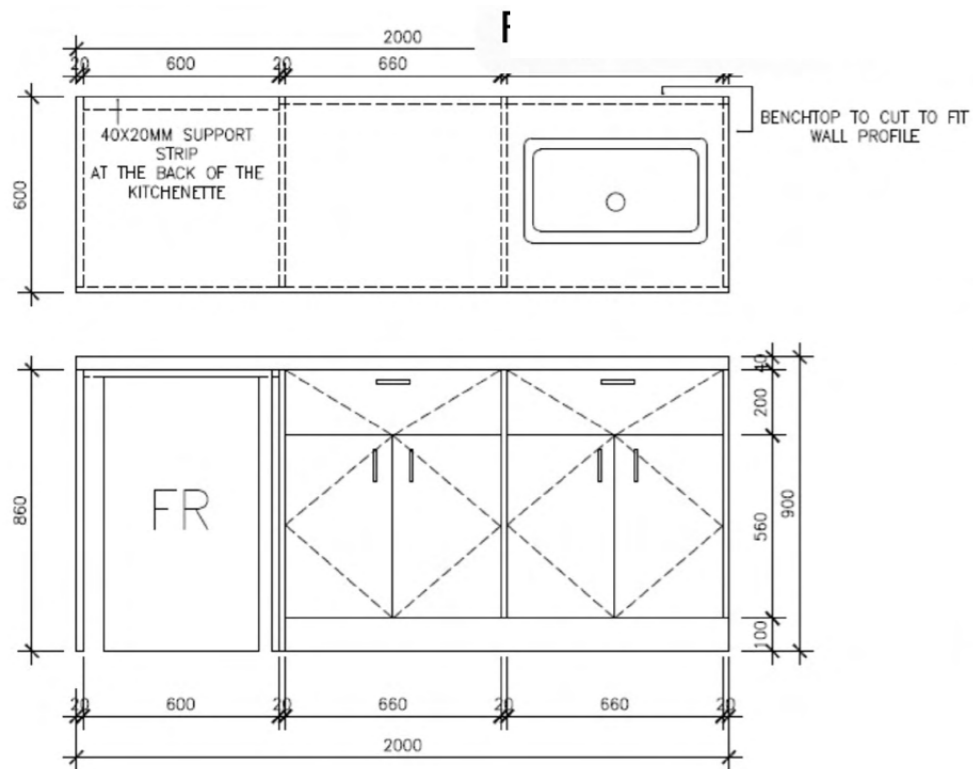

MICROWAVE KITCHENETTE

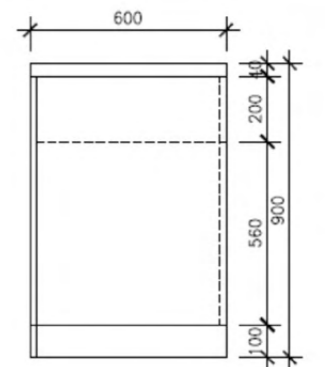
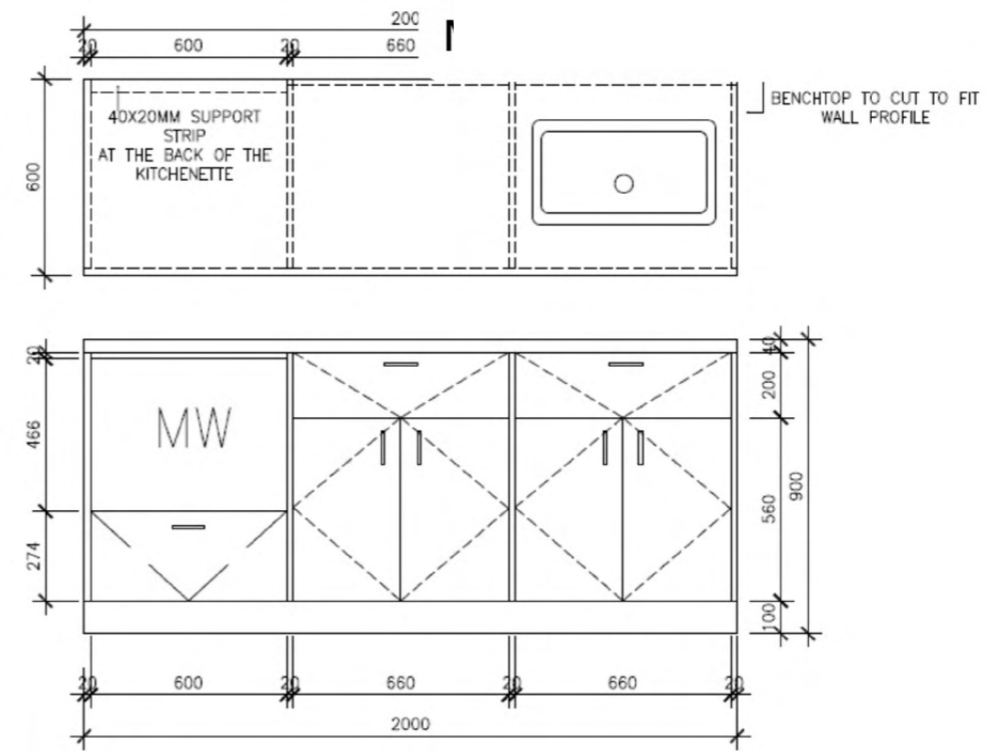

L-SHAPE KITCHENETTE

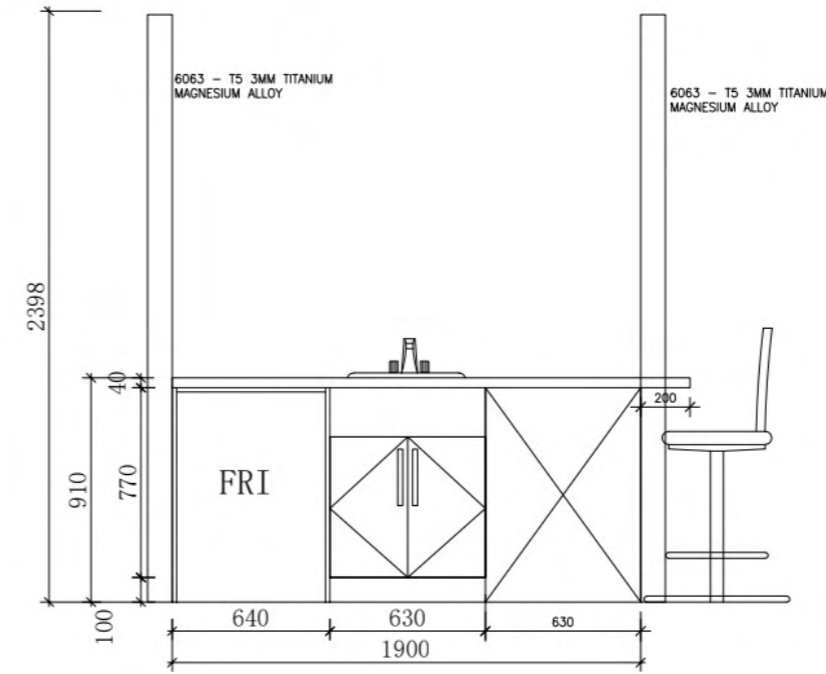

MINI L SHAPE KITCHENETTE

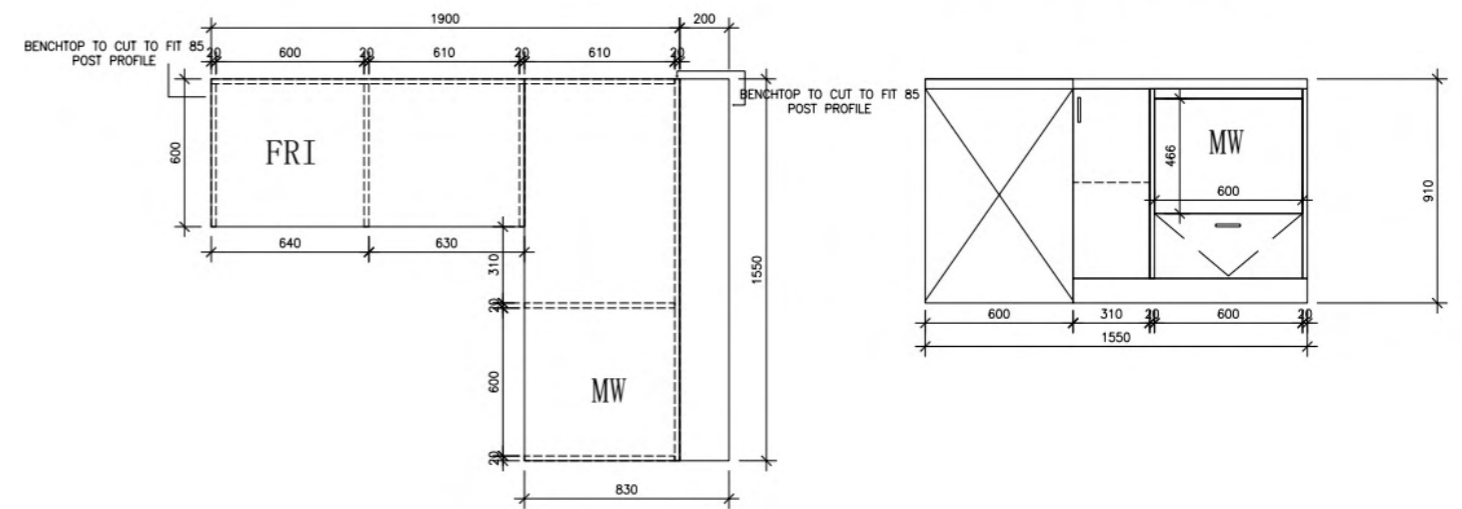

L-SHAPE KITCHEN

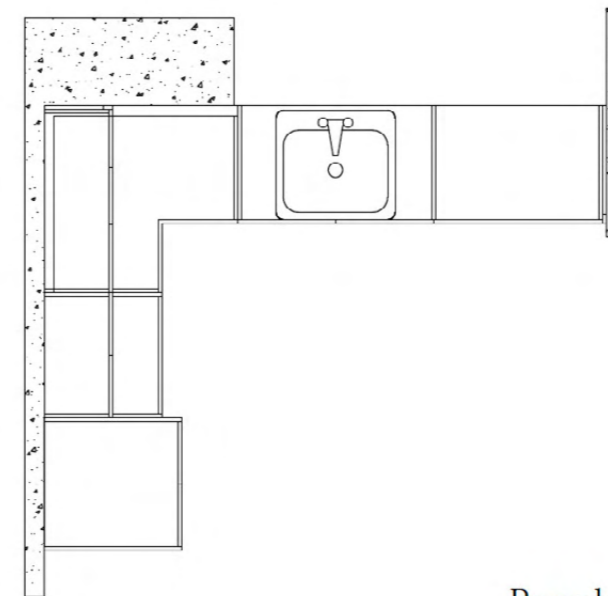
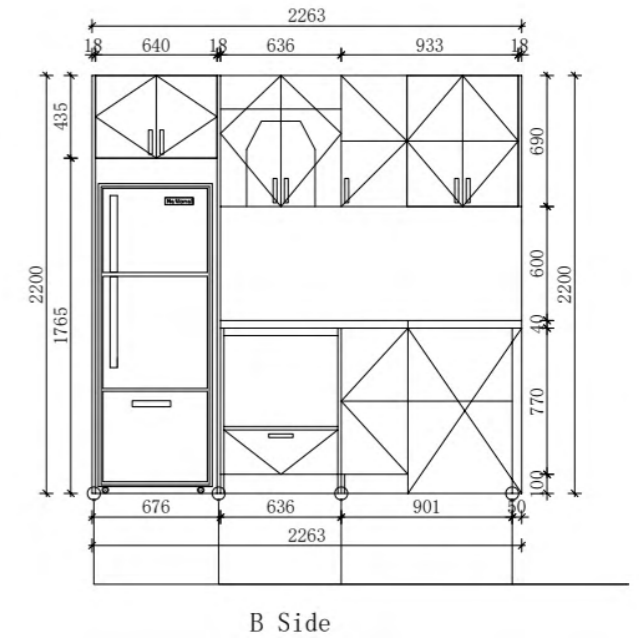
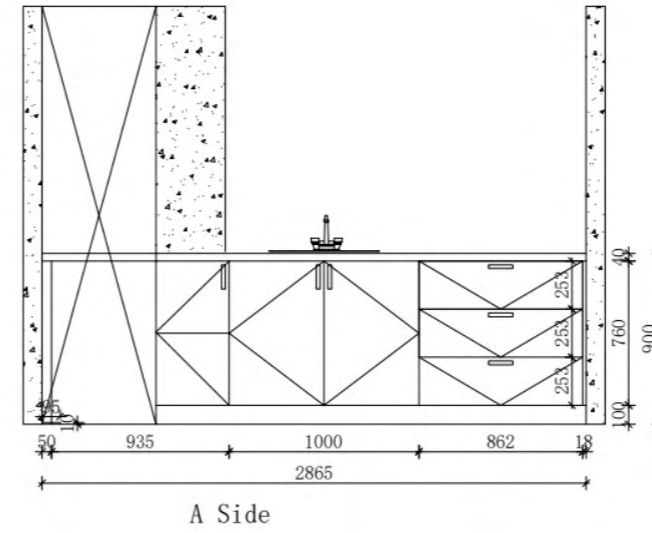

Benchtop View

U-SHAPE KITCHEN

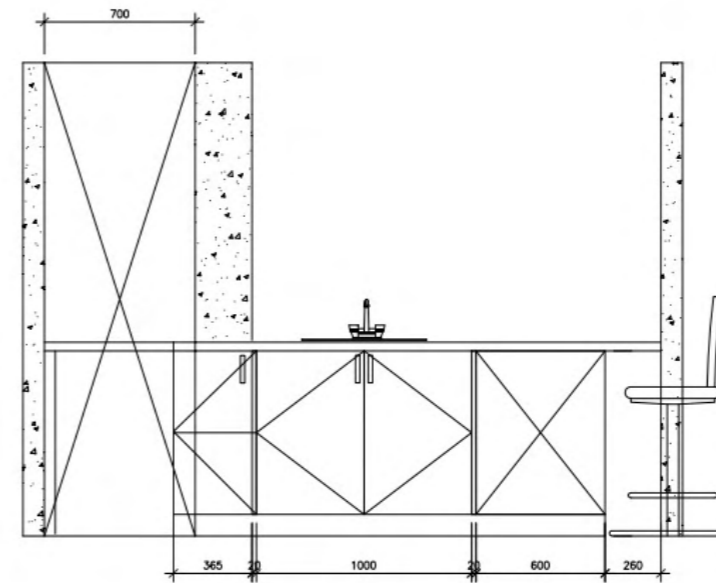

U SHAPE KITCHEN

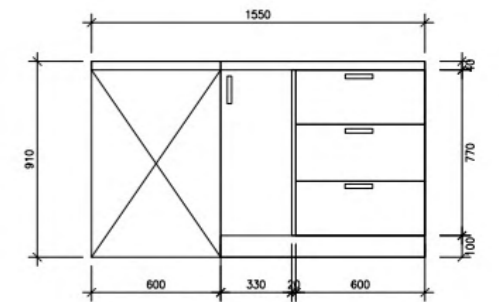
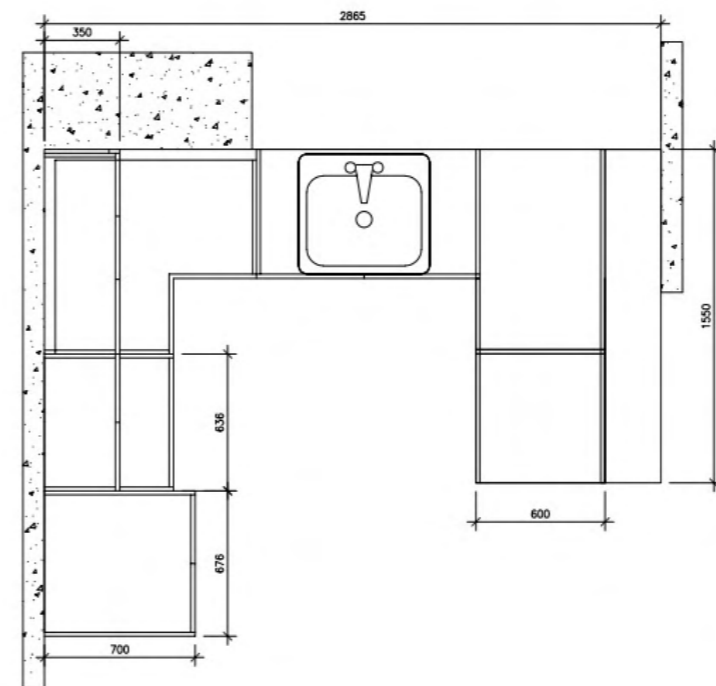

APPLIANCES

MINI FRIDGE



FRIDGE



COOKTOP



MICROWAVE / OVEN



RANGEHOOD

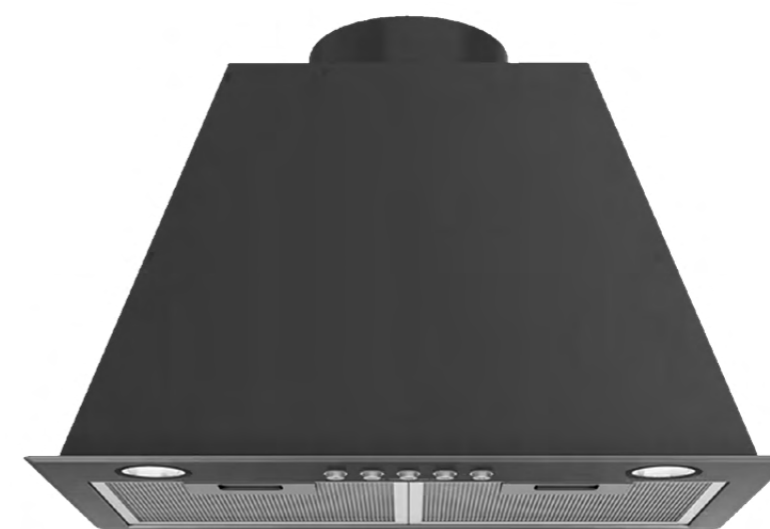

CABINET OPTIONS

CABINERY OPTIONS



BENCHTOP OPTIONS

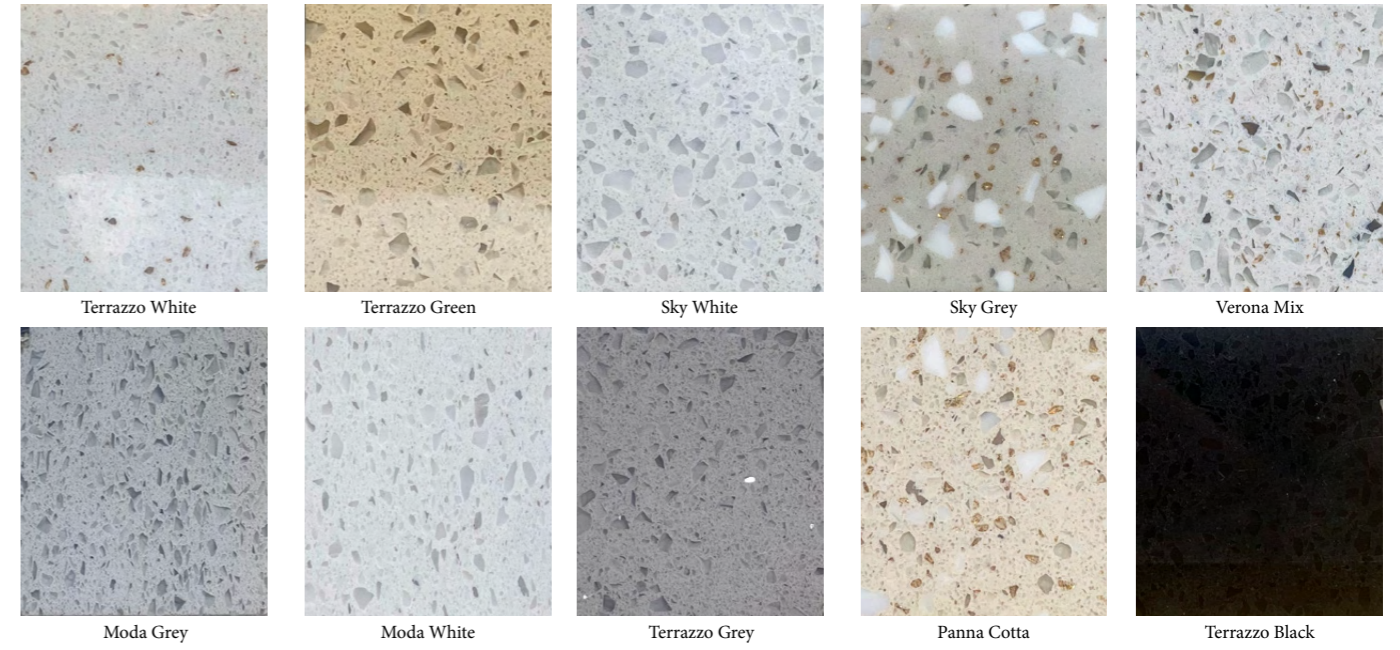

BLACK LIP PULL HANDLE
Standard option



BAR HANDLE
OPTION



SMART HOME PACKAGE

Upgrade your pod with our smart home package, which includes smart lights, motorised ceiling mounted TV, smart door locks, and smart bluetooth speakers

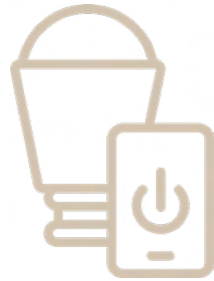

SMART LIGHTS

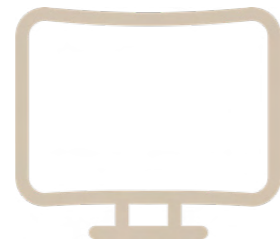

MOTORISED
CEILING MOUNTED TV



SMART DOOR LOCK



SMART BLUETOOTH
SPEAKERS

OFF-GRID SOLUTIONS

Take your pod off grid with our compost toilet, greywater management, water catchment/storage, and hot water solutions. Elsewhere can also refer customers to our solar & battery provider who have developed a flexible solar panel which integrates seamlessly with our curved roof design.

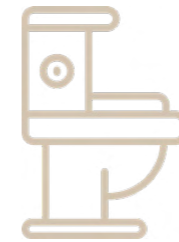

COMPOST TOILET



WATER STORAGE

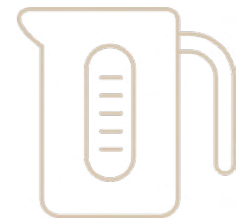

HOT WATER
SOLUTIONS



BATTERY

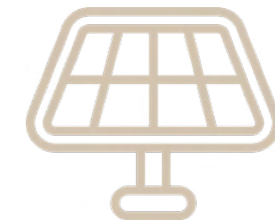

SOLAR PANEL

TRAILERS

Elsewhere can also provide a trailer for your pod to be installed on as a registered vehicle. This allows customers flexibility and mobility and will usually mean that building permits are not required (check with your local council).



LEASING OPTION

Financing tiny homes or studios can be a nightmare, especially if you don't have property to use as security. This is why Elsewhere has developed leasing arrangements for eligible customers.

Standard lease terms:

- 15% Commissioning fee which goes towards delivery and installation
- Flexible lease terms
- Monthly or weekly repayments
- Customer is eligible to make a buyout payment of 5% at any time
- Alternatively customers can continue to lease for as long as they wish, or
- End the lease by paying a decommissioning fee of 5-10%, Elsewhere will come and collect the pod
- Customers who wish to upgrade or update their pod at the end of their lease will receive a 10% discount on their subsequent purchase/lease.

DIMENSIONS

2.7 m



Size - Ext. Length (m)

Int. Length (m)	2.58 m
Int. Dept (m)	2.23 m
Int. Height (m)	2.40 m
Ext. Depth (m)	2.40 m
Ext. Depth incl. Structural 'Ribs' (m)	2.40 m
Ext. Height (m)	2.57 m
Ext. Height incl. Structural 'Ribs' (m)	2.72 m
Internal Area (sqm)	5.75 sqm
External Area (sqm)	6.60 sqm
External Area incl. Structural 'Ribs' (sqm)	6.60 sqm

4 m



Size - Ext. Length (m)

Int. Length (m)	3.83 m
Int. Dept (m)	2.23 m
Int. Height (m)	2.40 m
Ext. Depth (m)	2.40 m
Ext. Depth incl. Structural 'Ribs' (m)	2.70 m
Ext. Height (m)	2.57 m
Ext. Height incl. Structural 'Ribs' (m)	2.87 m
Internal Area (sqm)	8.54 sqm
External Area (sqm)	9.60 sqm
External Area incl. Structural 'Ribs' (sqm)	10.80 sqm

DIMENSIONS

6 m



Size - Ext. Length (m)

Int. Length (m)	5.83 m
Int. Depth (m)	2.23 m
Int. Height (m)	2.40 m
Ext. Depth (m)	2.40 m
Ext. Depth incl. Structural 'Ribs' (m)	2.70 m
Ext. Height (m)	2.57 m
Ext. Height incl. Structural 'Ribs' (m)	2.87 m
Internal Area (sqm)	13 sqm
External Area (sqm)	14.40 sqm
External Area incl. Structural 'Ribs' (sqm)	16.20 sqm

8 m



Size - Ext. Length (m)

Int. Length (m)	7.83 m
Int. Depth (m)	2.23 m
Int. Height (m)	2.40 m
Ext. Depth (m)	2.40 m
Ext. Depth incl. Structural 'Ribs' (m)	2.70 m
Ext. Height (m)	2.57 m
Ext. Height incl. Structural 'Ribs' (m)	2.87 m
Internal Area (sqm)	17.46 sqm
External Area (sqm)	19.20 sqm
External Area incl. Structural 'Ribs' (sqm)	21.60 sqm

10 m



Size - Ext. Length (m)

Int. Length (m)	9.83 m
Int. Depth (m)	2.23 m
Int. Height (m)	2.40 m
Ext. Depth (m)	2.40 m
Ext. Depth incl. Structural 'Ribs' (m)	2.70 m
Ext. Height (m)	2.57 m
Ext. Height incl. Structural 'Ribs' (m)	2.87 m
Internal Area (sqm)	21.92 sqm
External Area (sqm)	24.00sqm
External Area incl. Structural 'Ribs' (sqm)	27.00 sqm

12 m



Size - Ext. Length (m)

Int. Length (m)	11.83 m
Int. Depth (m)	2.23 m
Int. Height (m)	2.40 m
Ext. Depth (m)	2.40 m
Ext. Depth incl. Structural 'Ribs' (m)	2.70 m
Ext. Height (m)	2.57 m
Ext. Height incl. Structural 'Ribs' (m)	2.87 m
Internal Area (sqm)	26.38 sqm
External Area (sqm)	28.80sqm
External Area incl. Structural 'Ribs' (sqm)	32.40 sqm

DOUBLE WIDE

Double Wide 2.7m

Int. Length (m)	2.58 m
Int. Depth (m)	4.63 m
Int. Height (m)	2.40 m
Ext. Depth (m)	4.80 m
Ext. Depth incl. Structural 'Ribs' (m)	4.80 m
Ext. Height (m)	2.57 m
Ext. Height incl. Structural 'Ribs' (m)	2.72 m
Internal Area (sqm)	11.95 sqm
External Area (sqm)	13.20 sqm
External Area incl. Structural 'Ribs' (sqm)	13.20 sqm

Double Wide 4m

Int. Length (m)	3.83 m
Int. Depth (m)	4.63 m
Int. Height (m)	2.40 m
Ext. Depth (m)	4.80 m
Ext. Depth incl. Structural 'Ribs' (m)	4.80 m
Ext. Height (m)	2.57 m
Ext. Height incl. Structural 'Ribs' (m)	2.72 m
Internal Area (sqm)	11.95 sqm
External Area (sqm)	13.20 sqm
External Area incl. Structural 'Ribs' (sqm)	13.20 sqm

Double Wide 10m

Int. Length (m)	9.83 m
Int. Depth (m)	4.63 m
Int. Height (m)	2.40 m
Ext. Depth (m)	4.80 m
Ext. Depth incl. Structural 'Ribs' (m)	5.10 m
Ext. Height (m)	2.57 m
Ext. Height incl. Structural 'Ribs' (m)	2.87 m
Internal Area (sqm)	45.51 sqm
External Area (sqm)	48.00 sqm
External Area incl. Structural 'Ribs' (sqm)	51.00 sqm

Double Wide 12m

Int. Length (m)	11.83 m
Int. Depth (m)	4.63 m
Int. Height (m)	2.40 m
Ext. Depth (m)	4.80 m
Ext. Depth incl. Structural 'Ribs' (m)	5.10 m
Ext. Height (m)	2.57 m
Ext. Height incl. Structural 'Ribs' (m)	2.87 m
Internal Area (sqm)	54.77 sqm
External Area (sqm)	57.60 sqm
External Area incl. Structural 'Ribs' (sqm)	61.20 sqm

Double Wide 6m

Int. Length (m)	5.83 m
Int. Depth (m)	4.63 m
Int. Height (m)	2.40 m
Ext. Depth (m)	4.80 m
Ext. Depth incl. Structural 'Ribs' (m)	5.10 m
Ext. Height (m)	2.57 m
Ext. Height incl. Structural 'Ribs' (m)	2.87 m
Internal Area (sqm)	26.99 sqm
External Area (sqm)	28.80 sqm
External Area incl. Structural 'Ribs' (sqm)	30.60 sqm

Double Wide 8m

Int. Length (m)	7.83 m
Int. Depth (m)	4.63 m
Int. Height (m)	2.40 m
Ext. Depth (m)	4.80 m
Ext. Depth incl. Structural 'Ribs' (m)	5.10 m
Ext. Height (m)	2.57 m
Ext. Height incl. Structural 'Ribs' (m)	2.87 m
Internal Area (sqm)	45.51 sqm
External Area (sqm)	48.00 sqm
External Area incl. Structural 'Ribs' (sqm)	51.00 sqm

DECK & PERGOLA

4m Pod

Length (m)	2.10 m
Depth (m)	2.50 m
Area (sqm)	5.25 m

6m Pod

Length (m)	4.10 m
Depth (m)	2.50 m
Area (sqm)	10.25 m

8m Pod

Length (m)	6.10 m
Depth (m)	2.50 m
Area (sqm)	15.25 m

10m Pod

Length (m)	8.10 m
Depth (m)	2.50 m
Area (sqm)	20.25 m

12m Pod

Length (m)	10.10 m
Depth (m)	2.50 m
Area (sqm)	25.25 m

PRICELIST

2.7 m



Studio Office
\$32,659
Tiny Home
N/A

4 m



Studio Office
\$43,580
Micro Home
\$60,713

6 m



Studio Office
\$59,113
Tiny Home
\$79,328

8 m



Studio Office
\$74,205
Tiny Home
\$95,080

10 m



Studio Office
\$89,298
Tiny Home
\$110,832

12 m



Studio Office
\$106,442
Tiny Home
\$128,646

elsewhere

INCLUSIONS	STUDIO OFFICE	TINY HOME	DOUBLE WIDE
Delivery (Metro)	Included	Included	Included
Standard Installation	Included	Included	Included
Ventilation System	Included	Included	Included
2.5kw Split System	Included	Included	Included
Standarda Kitchenette		Included	
Standarda Bathroom		Included	

DOUBLE WIDE (4.8m)

2.7 m	\$ 57,051
4 m	\$ 75,529
6 m	\$100,515
8 m	\$ 125,018
10 m	\$ 149,523
12 m	\$ 176,739

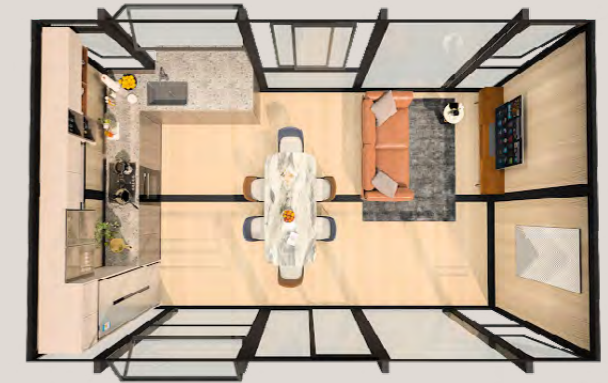

OPTIONAL EXTRAS

INTERNAL	Price (ex GST)	EXTERNAL	Price (ex GST)
Micro Kitchenette	\$ 2,664	Glass side Wall	\$ 1,618
Standard Kitchenette (w/fridge)	\$ 5,446	Large CEP Wall Panel (optional window)	\$ 2,559
Standard Kitchenette (w/microwave)	\$ 6,814	Small CEP Wall Panel (optional window)	\$ 1,186
L Shape Kitchenette	\$ 9,110	Small Mirror/Frosted Glass Panel	\$ 241
L Shape Kitchen	\$ 18,246	Large Mirror/Frosted Glass Panel	\$ 361
U Shape Kitchen	\$ 20,836	Large Openable Window or Door	\$ 1,967
Overhead Cabinetry	\$ 2,182	Large Bi-fold Window or Door	\$ 2,559
Outdoor Bar Style Bench	\$ 1,391	Small Openable Window or Door	\$ 1,186
Standard Bathroom	\$ 13,923	TRAILERS	
Oversize Bathroom (2.9m variant)	\$ 20,885	Trailer - 4m	\$ 13,932
Euro Laundry (w/ washer/dryer combo)	\$ 2,287	Trailer - 6m	\$ 15,054
Storage Cabinetry (per metre)	\$ 1,832	Trailer - 8m	\$ 16,176
		Trailer - 10m	\$ 17,298
CEP Partition - Single (per metre)	\$ 1,132		
CEP Partition - Double (per metre)	\$ 1,792	BALCONIES / DECKS	
Glass Partition (per metre)	\$ 1,510	Rooftop Staircase	\$ 7,155
		Rooftop Balcony - 4m	\$ 13,938
Integrated Bluetooth Speakers x 2	\$ 3,245	Rooftop Balcony - 6m	\$ 18,863
Integrated Bluetooth Speakers x 4	\$ 4,974	Rooftop Balcony - 8m	\$ 23,788
Smart Door Lock	\$ 676	Rooftop Balcony - 10m	\$ 28,713
Motorised Ceiling Mounted TV	\$ 1,153	Rooftop Balcony - 12m	\$ 33,439
LED Mood Lighting x2	\$ 568	Rooftop Balcony - 4mdw	\$ 24,646
Slimline Fan	\$ 774	Rooftop Balcony - 6mdw	\$ 33,418
		Rooftop Balcony - 8mdw	\$ 42,189
Blind - Large Window	\$ 442	Rooftop Balcony - 10mdw	\$ 50,961
Blind - Small Window	\$ 491	Rooftop Balcony - 12mdw	\$ 59,389
Flyscreen - Full Panel	\$ 1,780		
Flyscreen - Sliding Door	\$ 937		
Flyscreen - Window Large Panel	\$ 697		
Flyscreen - Window Small Panel	\$ 456		

	Price (ex GST)		Price (ex GST)
Deck Staircase (Small)	\$ 1,917	Water Catchment (per panel)	\$ 568
Deck Staircase (Large)	\$ 2,615	Breezeway (per metre)	\$ 7,203
Deck - 2.1m x 2.5m (4m pod)	\$ 7,466	BAL40 Fixed Screens - Small Panel	\$ 560
Deck - 4.1m x 2.5m (6m pod)	\$ 11,557	BAL40 Fixed Screens - Large Panel	\$ 628
Deck - 6.1m x 2.5m (8m pod)	\$ 15,649	Roller Shutters - Small Panel	\$ 2,053
Deck - 8.1m x 2.5m (10m pod)	\$ 19,741	Roller Shutters - Large Panel	\$ 2,822
Deck - 10.1m x 2.5m (12m pod)	\$ 23,833		
Deck & Pergola - 2.1m x 2.5m (4m pod)	\$ 13,729	OFFGRID SOLUTIONS	
Deck & Pergola - 4.1m x 2.5m (6m pod)	\$ 22,814	Compost Toilet	\$ 4,345
Deck & Pergola - 6.1m x 2.5m (8m pod)	\$ 31,899	Incineration Toilet	\$ 8,494
Deck & Pergola - 8.1m x 2.5m (10m pod)	\$ 40,985	Greywater System	\$ 3,037
Deck & Pergola - 10.1m x 2.5m (12m pod)	\$ 50,070	Electric Heat Pump (starts at)	\$ 3,831
		Solar + Battery (starts at)	\$16,524
		Solar Trailer System (starts at)	\$ 20,655
EXTERNAL BLINDS		Water Storage System	\$ 6,280
Pergola Screen - Side	\$ 1,278		
Pergola Screen - 1 Panel	\$ 1,141	OTHER	
Pergola Screen - Double Panel	\$ 1,730	Cross Structure Plumbing (per metre)	\$ 246
Full Pergola Screens 4m pod	\$ 3,696	Multi-level Plumbing	\$ 2,452
Full Pergola Screens 6m pod	\$ 4,285	Planning Permits	\$ 1,964
Full Pergola Screens 8m pod	\$ 5,976	Double stack	\$ 14,624
Full Pergola Screens 10m pod	\$ 6,565	Cantilever	\$ 14,624
Full Pergola Screens 12m pod	\$ 7,705	Interior Design (Consultation)	\$ 345
Pod Panel Screen - Small	\$ 909	Professional Photography	\$ 896
Pod Panel Screen - Large	\$ 1,141	Building Permit Docs: (Engineering Certificates + Energy Reports)	\$ 6,197
GUTTERS			
Gutters (per panel)	\$ 333		
Guttering - 4m pod	\$ 665		
Guttering - 6m pod	\$ 1,330		
Guttering - 8m pod	\$ 1,994		
Guttering - 10m pod	\$ 2,659		
Guttering - 12m pod	\$ 3,323		



elsewhere

www.elsewherepods.com